

Engineering Handbook

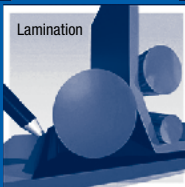
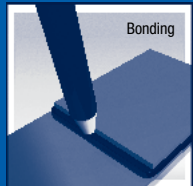
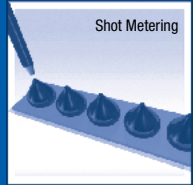
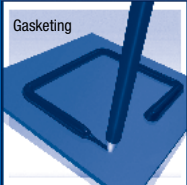
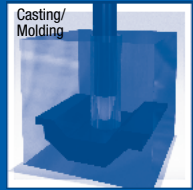

Introduction

The Engineering handbook has been prepared to assist the user to better understand the types of equipment used to meter, mix and dispense a wide variety of resin systems. Included are illustrations of the most common types of metering pumps, mixers, dispense valves and feed systems employed. Due to space considerations, not every design or configuration could be included.

Additional machine design considerations including material parameters, useful conversion charts, handy formulas and typical application information are provided to further enhance the user's knowledge of dispensing equipment.

Material for this engineering handbook has been carefully compiled. The handbook utilizes the best and latest available information, and we believe it to be extremely accurate. However, Graco cannot be responsible for errors.

Questions, comments and requests for additional copies of this engineering handbook should be directed to:

Graco Ohio Inc.
8400 Port Jackson Ave. NW
North Canton, OH 44720
Phone (330) 966-3000
Fax (330) 494-5383

Visit www.graco.com for additional machine design configurations, animated illustrations, videos, and electronic calculators.

Table of Contents

I. Illustrations	
a. Metering Pump Technology	2
b. Fixed & Variable Ratio Designs	10
c. Rotary Pump Flow Diagrams	12
d. Mixer Technology	14
e. Dispense Valve Technology	18
f. Material Feed Systems	26
II. How Materials Affect Equipment Design	
a. Viscosity	28
b. Fillers	32
III. Conversions And Formulas	
a. Temperature (°F to °C)	36
b. Pressure (psi, bar, kPa)	38
b. Useful Conversion Factors	40
c. Formulas For Geometric Shapes	41
d. Vacuum	42
IV. Application Data And Calculations	
a. Power Factor	46
b. Air Cylinder Consumption	47
c. Volumetric Content And Ratios Of Standard Material Hoses	48
d. Volume Of Dots	50
e. Volume Of Beads	52
f. Ratio Of "A" To "B"	54
g. Posiload® Pump Sizing	55
h. Shot Capability Of Standard Posiload® Piston Pumps	56
i. Gear Pump Select Chart	57
j. Process Capability CP & CPK	60
V. Abbreviations	
a. Common Abbreviations And Symbols	62
VI. Application Glossary	64
a. Automation Terms	65

Metering Pump Technology

Posiload® Piston Metering Pump

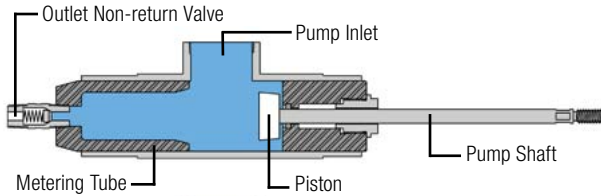

The piston is fully retracted and material enters the metering tube through the pump inlet.

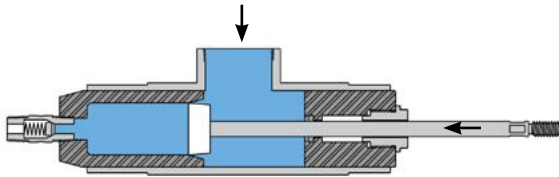

The piston advances to the entrance of the metering tube and closes it off, acting as an inlet non-return valve.

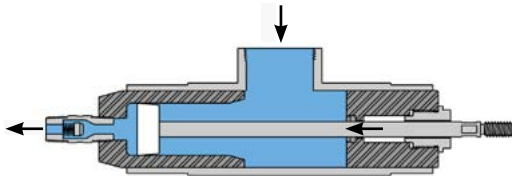

As the piston travels through the metering tube, the outlet non-return valve opens and material is accurately displaced. The length of metering stroke is adjustable.

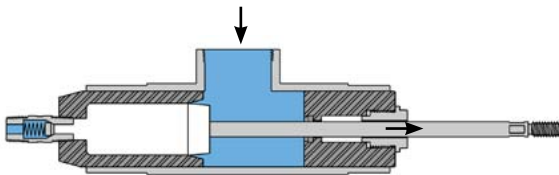

To reload the pump, the piston quickly withdraws from the metering tube closing the outlet non-return valve, and creating a vacuum to assist material loading.

Posiload® Rod Metering Pump

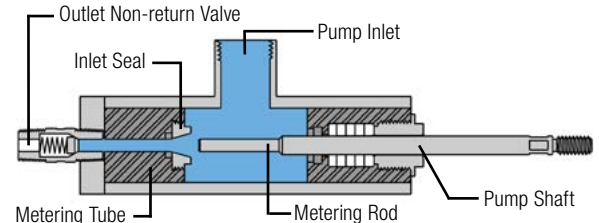

The metering rod is fully retracted and material enters the metering tube through the pump inlet.

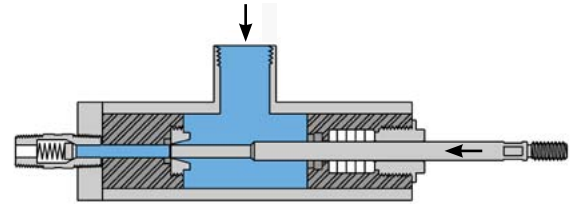

The metering rod advances to the seal at the entrance of the metering tube and closes it off, acting as an inlet non-return valve.

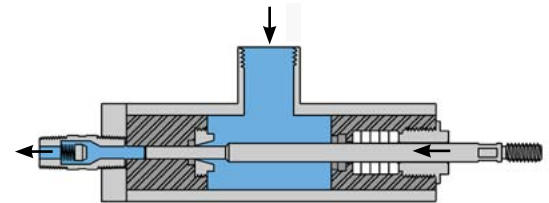

As the metering rod travels through the metering tube, the outlet non-return valve opens and material is accurately displaced. The length of metering stroke is adjustable.

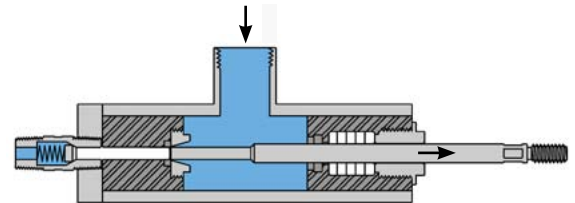

To reload the pump, the metering rod quickly withdraws from the metering tube, closing the outlet non-return valve, and creating a vacuum to assist material loading.

Metering Pump Technology

Rod Metering Pump

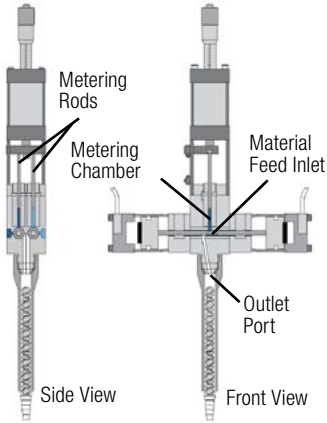

To load the valve, the metering rod is retracted to a precisely set position determining the volume of each material. The outlet ports are blocked and material feed inlets are opened. Materials are transferred into the metering chamber by a pressurized feed system.

During the dispense delay, the balanced spool assemblies shift. The material inlets are blocked and the outlet ports are opened. The metering rod remains in the retracted position.

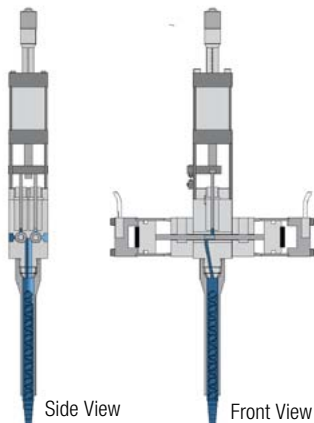
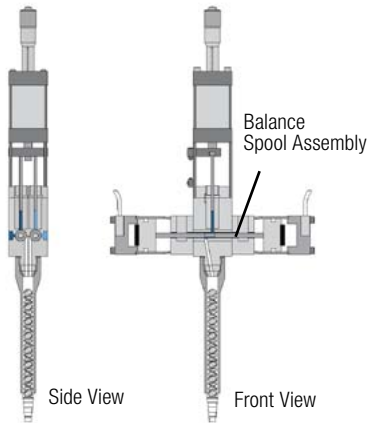

Dispensing begins when the metering rod is driven down. "A" and "B" materials are simultaneously dispensed from the metering chamber into the disposable mixer. Each component is dispensed at the predetermined ratio.

Conventional Rod Pump

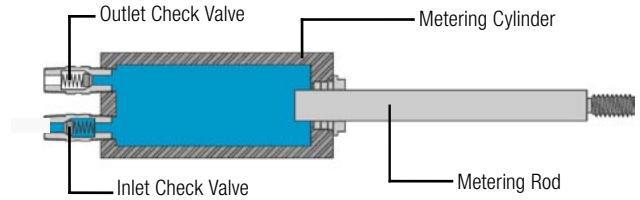

The metering rod is fully retracted and material enters the metering cylinder through the inlet check valve.

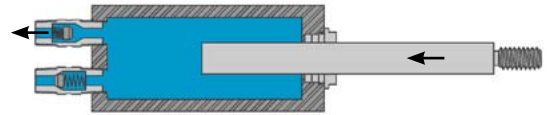

The metering rod advances through the metering cylinder accurately displacing material through the outlet check valve.



The metering rod advances to an adjustable length of stroke depending on the shot size desired.

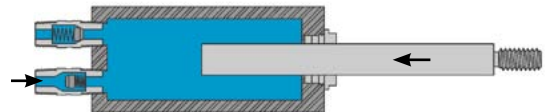

To reload the pump, the metering rod retracts from the metering cylinder closing the outlet check valve and drawing material through the inlet check valve.

Metering Pump Technology

Front Load Metering Pump

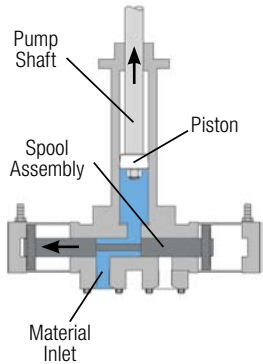

To load the valve, the pump shaft is retracted to a precisely set position determining the volume of each material. The outlet port is blocked and material feed inlet is opened. Material is transferred into the metering chamber by a pressurized feed system.

During the dispense delay, the spool assembly shifts. The material inlet is blocked and the outlet port is opened. The pump shaft remains in the retracted position.

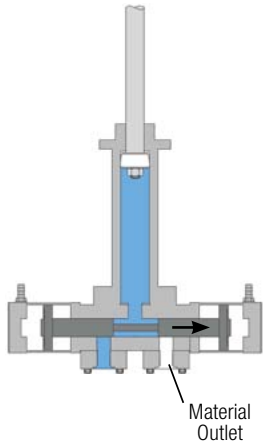

Dispensing begins when the pump shaft is driven down. The material is dispensed from the metering chamber to the material outlet and out to a mixing head.

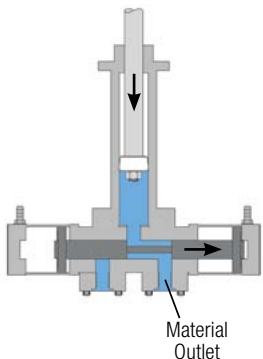

Double Ball Check Pump

This type of pump utilizes two ball checks to produce double-acting pumping action to dispense on both the down and up stroke. At the top of the stroke, the piston rod is ready to move down and both the upper and lower ball checks are momentarily closed.

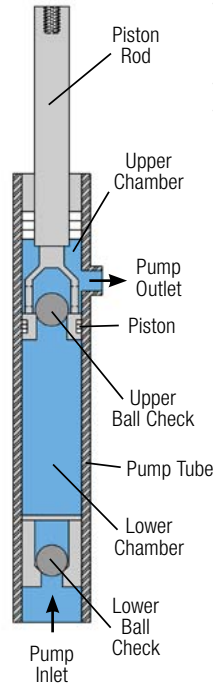

As the piston rod pushes the piston down through the pump tube, the lower ball check remains closed preventing material flow out the pump inlet. The material in the lower chamber lifts the upper ball check from its seat and material flows into the upper chamber. Since the upper chamber has less volume (approximately one-half) than the lower chamber due to the displacement of the piston rod, material is forced through the pump outlet.

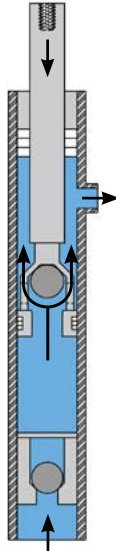

At the bottom of the stroke, the piston rod is ready to move up and both the upper and lower ball checks again are momentarily closed.

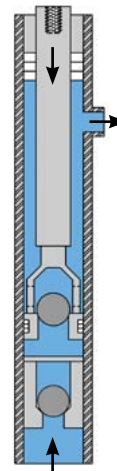

As the piston rod pulls the piston up through the pump tube, the upper ball check remains closed preventing material flow from the lower chamber into the upper chamber. A vacuum draws the lower ball check off its seat and material flows through the pump inlet into the lower chamber. At the same time, material in the upper chamber is forced out the pump outlet as new material is drawn into the pump inlet.

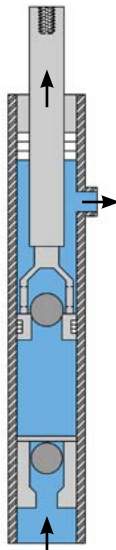

Metering Pump Technology

Progressive Cavity Pump

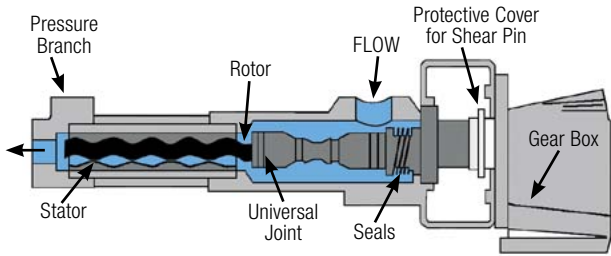

Rotor

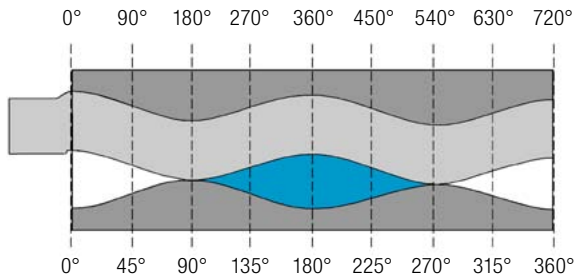

Stator



Progressive Cavity pumps are in the family of screw pumps. They are most effective when used to meter or transfer medium to high viscosity liquids filled with abrasive compounds such as glass beads, glass balloons and metallic or organic fillers, i.e. quartz, aluminum oxide and titanium oxide. Fluid flow starts from the entrance, at the top on the right, to the left as the rotor revolves inside the stator. The stator is a twisted cavity with an oval-shaped cross-section. It is usually made of natural or synthetic rubber, steel, or plastic. The rotor is usually steel. As the rotor turns a series of cavities are continuously formed that progress down the length of stator until discharged. A slight fluid pulse can be detected at low rpms. The progressive cavity pumps can be used for one or both components.

Gear Pumps

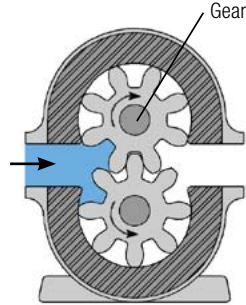

Material is drawn into the pump inlet to be metered by the gear teeth around the inside circumference of the pump.

The gear teeth carry the material through the pump with the accuracy of volumetric displacement subject to how close tolerance is maintained between the teeth and the inside walls of the pump.

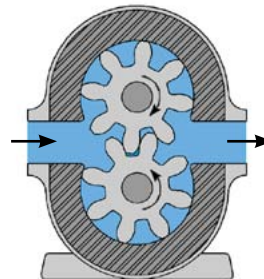
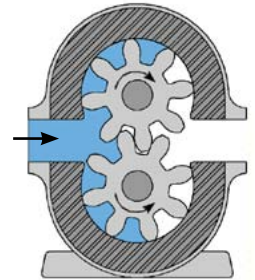

Metered material is discharged through the pump outlet. Both the size of the pump and the rotational speed determine the volume to be discharged subject to any slippage within the pump.

Fixed & Variable Ratio Designs

Fixed Ratio

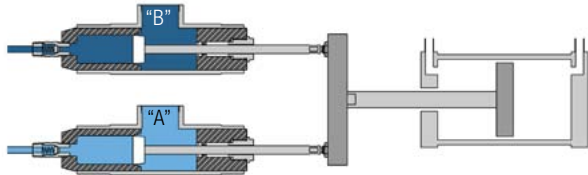

The volumetric ratio of "A" to "B" is determined by the size of the metering pumps. To change the ratio requires a pump replacement with one of another size.

Variable Ratio

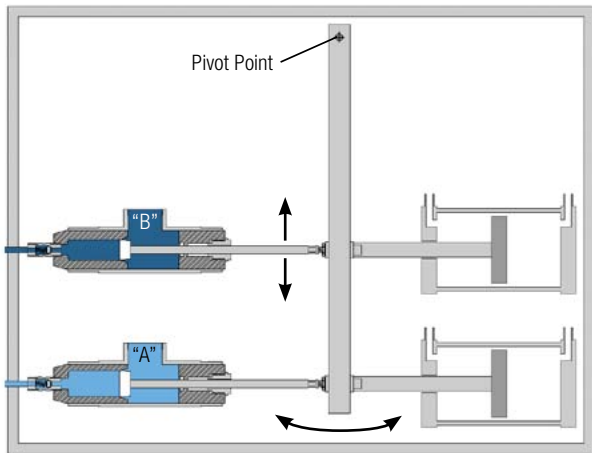

The volumetric ratio of "A" to "B" is determined by both the size of the metering pumps and where the "B" pump is located along the pivoting beam. The closer the "B" pump is to the pivot point, the shorter its stroke and the wider the ratio of "A" to "B".

Compact Variable Ratio

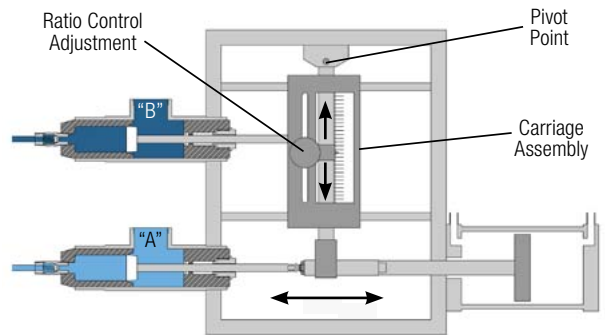

The volumetric ratio of "A" to "B" is determined by both the size of the metering pumps and the length of the stroke of the "B" pump. Both pumps are fixed in position but a ratio control adjustment determines the length of the metering stroke of the "B" pump in relationship to the "A" pump metering stroke.

The "B" pump shaft is connected to a carriage assembly with an adjustable drive beam connector that controls the length of travel of the carriage assembly. This in turn controls the length of stroke of the "B" pump.

By moving the ratio control adjustment toward the pivot point, the shorter the stroke of the "B" pump and the wider the ratio of "A" to "B". By moving the ratio control adjustment away from the pivot point, the longer the stroke of the "B" pump and the closer the ratio of "A" to "B".

Rotary Pump Flow Diagrams

Process Flow

Diagram 'A'

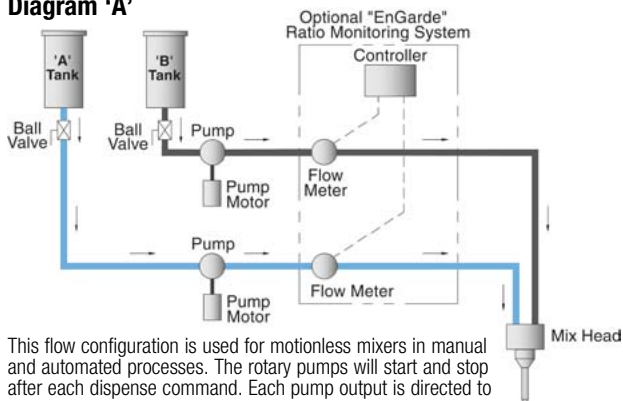

This flow configuration is used for motionless mixers in manual and automated processes. The rotary pumps will start and stop after each dispense command. Each pump output is directed to a pneumatically-operated mix head or to a mix head with spring-loaded non-drip valves.

Diagram 'B'

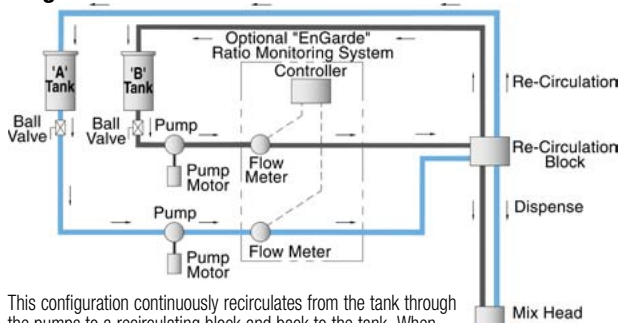

This configuration continuously recirculates from the tank through the pumps to a recirculating block and back to the tank. When mix material is demanded, the recirculation block activates and sends the metered streams through individual hoses to a remote mix head.

Diagram 'C'

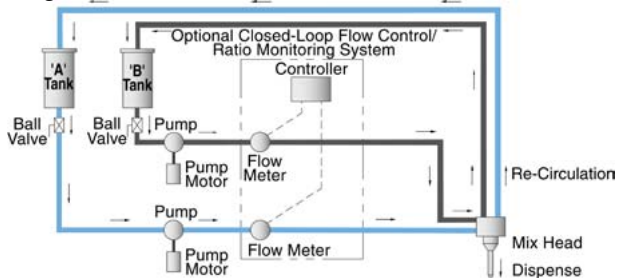

This configuration is similar to the diagram 'B'. However, the recirculation block and mix head are one unit, allowing materials to continuously move through the entire system. The mix head can be either motionless or dynamic.

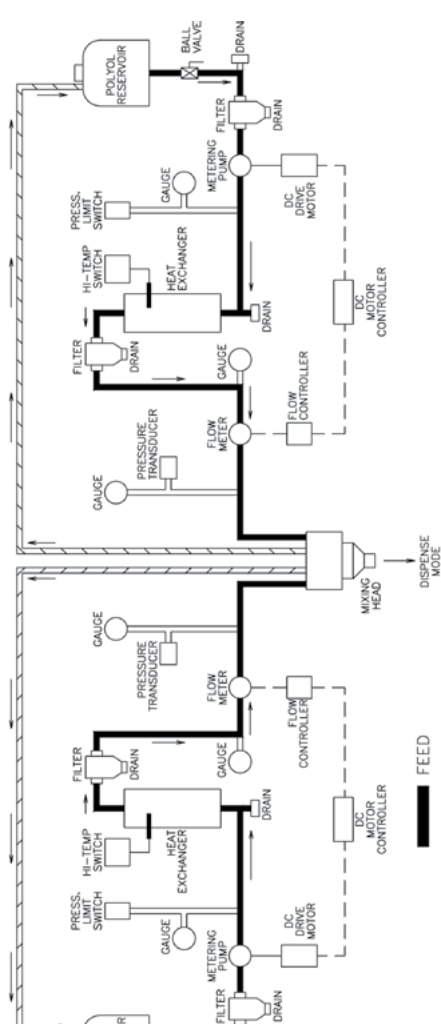

A and B components continuously flow from reservoirs through conditioning subsystems, rotary pump mix head and back to reservoirs, thus providing very accurate temperature, flow control and continuous feedback on process parameters. When mixed material is required, the 3-way ball valves in the mix head are actuated to direct the fluid flow into the in-line rotary mix chamber. At the completion of the mixed material delivery, the ball valves rotate back to the circulation mode. See pages 16 and 17 for mix head descriptions.

Mixer Technology

Motionless Mixer

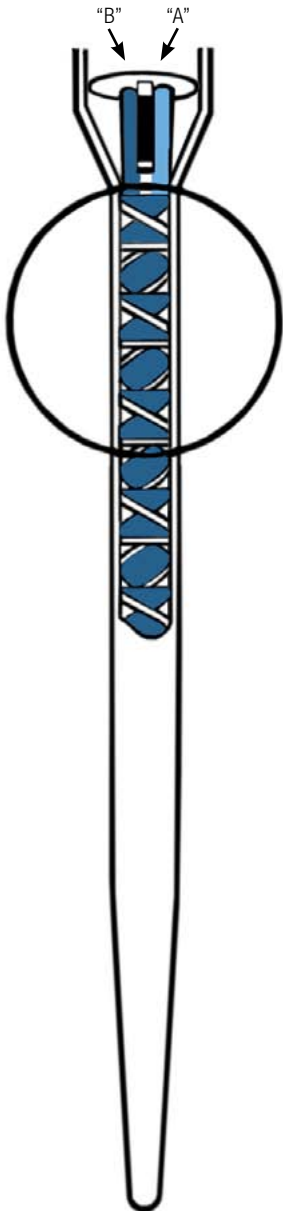

DIVISION



Number
of Striations

The most common motionless mixer for reactive resin systems features a series of alternating right- and left-hand helical elements oriented at 90° to one another. These mixers have no moving parts and are available in a wide variety of sizes.

They operate on the principle that the main stream of "A" and "B" components is broken up into minor streams. The materials are divided, reoriented, brought back together, and then the cycle is repeated again and again until the components are thoroughly mixed.

These mixers are available in all-plastic construction for low cost and disposability. Others have removable plastic elements in metal housings, removable metal elements in metal housings and non-removable metal elements in metal housings. Non-disposable mixers will typically require solvent or base purging to clean them but are reusable.

Mixing Technology

Dynamic Mixer

These are closed system mixing devices which use high shear to fully mix the "A" and "B" components. A variety of mixer designs are available with the pin/blade and helical design being most common. Various size mix chambers and rotational speeds are offered to accommodate a wide variety of materials and applications. Solvent and air purging are typically used to flush the reactive material from the mix chamber.

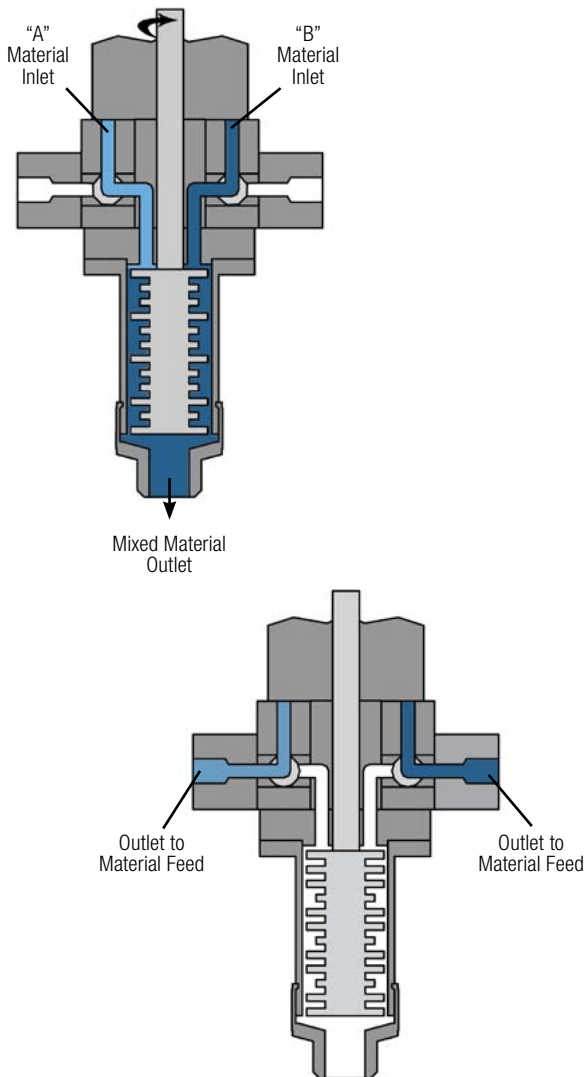

Dynamic Disposable Mix Head

The Dynamic Disposable Mix Head is a two component mix head primarily designed to dynamically blend difficult to mix low viscosity reactive chemistries, such as polyurethane elastomers and foams. Each of two metered streams of material is fed to the mix head.

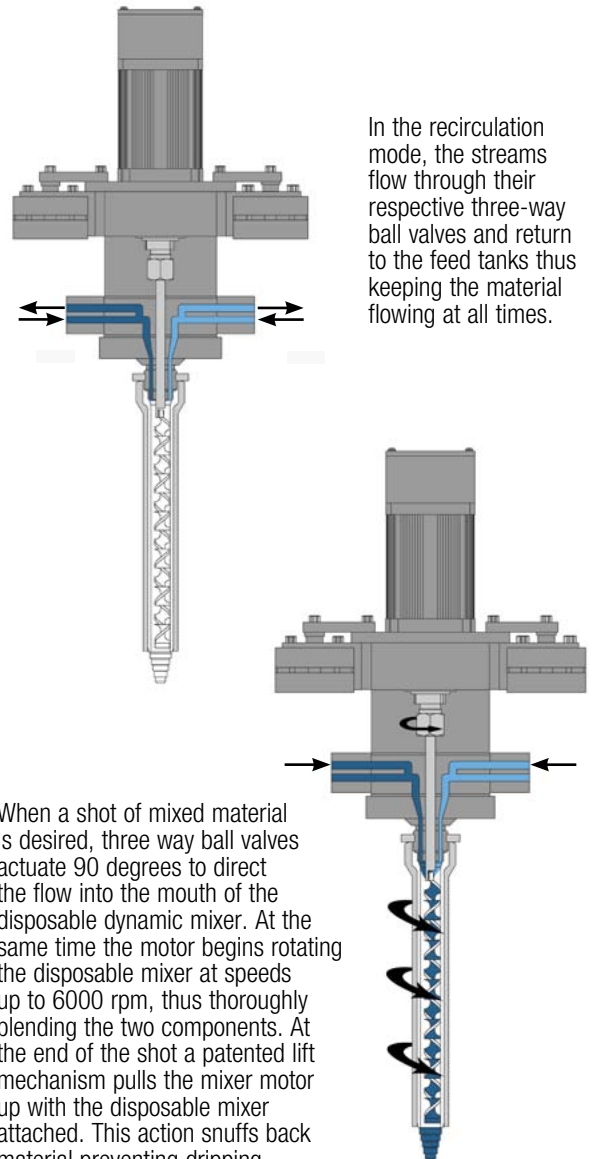

Dispense Valve Technology

Automatic Dispense Valve

This pneumatically actuated valve keeps the "A" and "B" components separate until they are inside the mixer. It has an adjustable snuffback action.

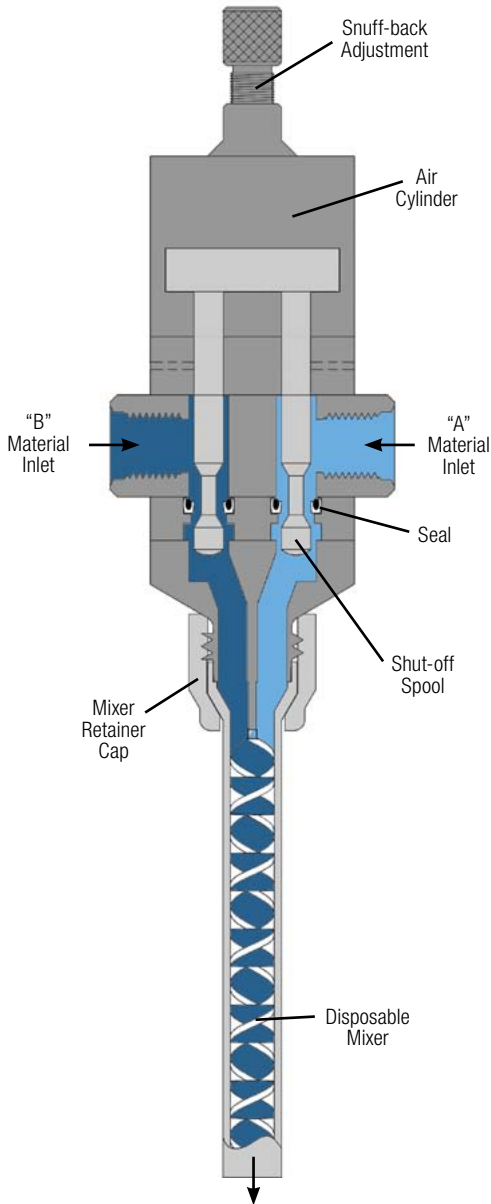

Non-Drip Dispense Valve

This mix valve keeps the "A" and "B" materials separate within the valve and features quick disconnect, spring loaded, non-drip valves. It is available in standard 1:1 and 10:1 models. Ideal for applications not requiring precise shot size control.

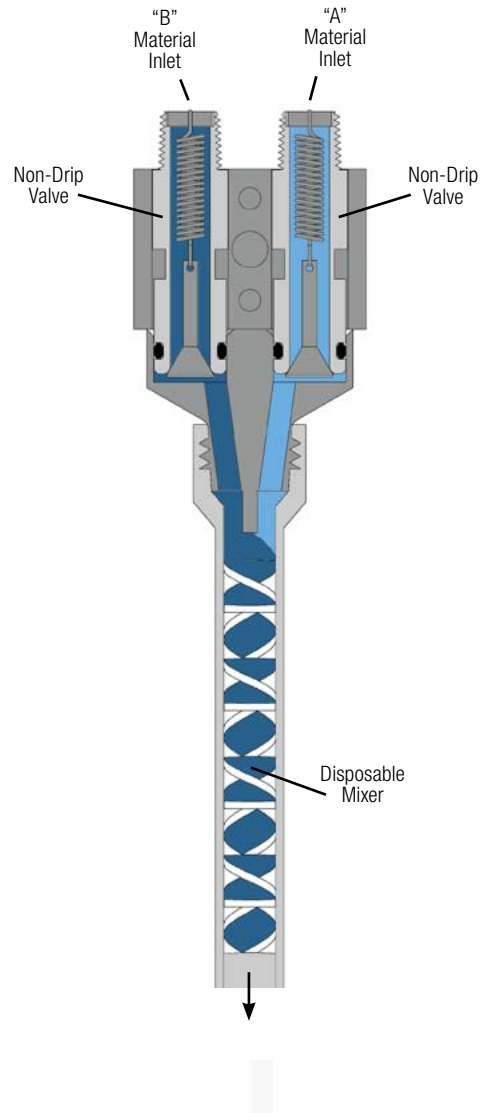

Dispense Valve Technology

Over/Under Injection Block

This injection block is typically used when there is a high ratio difference between the "A" and "B" components. It introduces the low volume "B" component into the center of the "A" stream just prior to the motionless mixer. Solvent and air purging are typically used to flush the injection block and mixer.

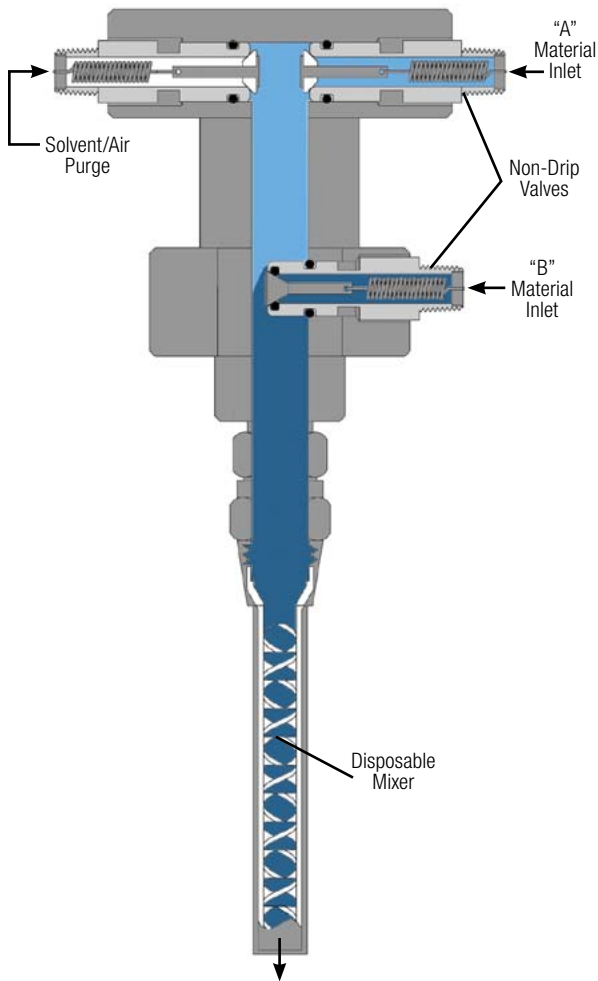

High Pressure Impingement Mix Heads

These are closed system mixing devices which use high-pressure impingement of the "A" and "B" components and the resultant turbulence to accomplish a thorough mixing. Solvent purging is not required as the mixed material is mechanically purged by a close tolerance rod. A wide variety of sizes are available to handle various flow rate requirements.

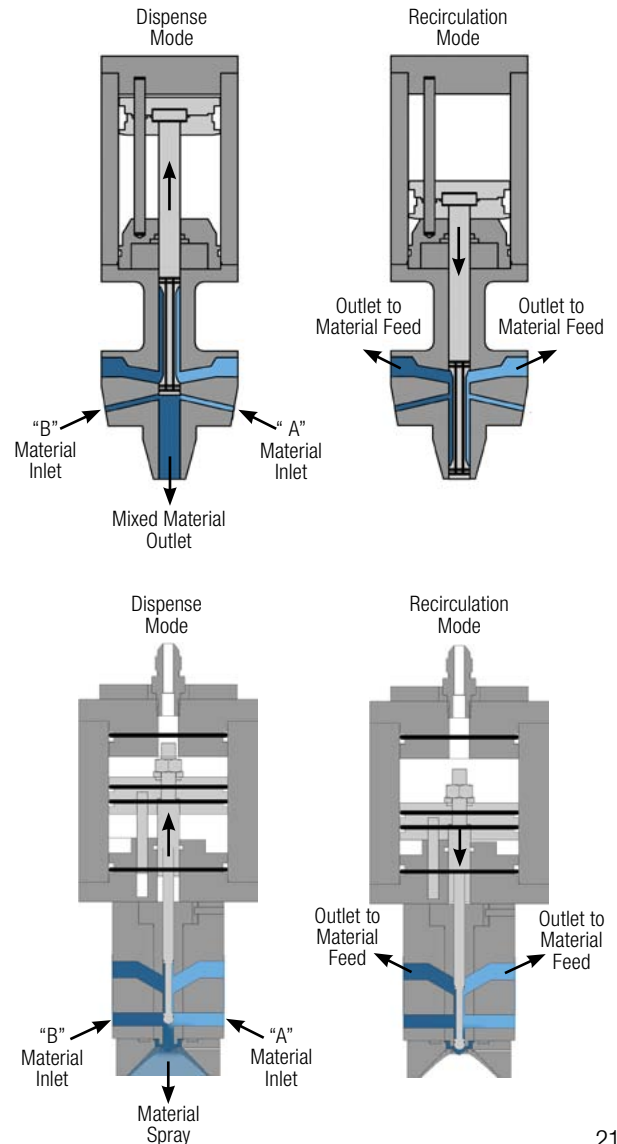

Dispense Valve Technology

Snuffer On/Off Dispense Valve

Material flow commences on the forward stroke of the valve spool. When the spool retracts, a vacuum is created and an adjustable, dripless snuff back occurs at the dispense nozzle outlet.

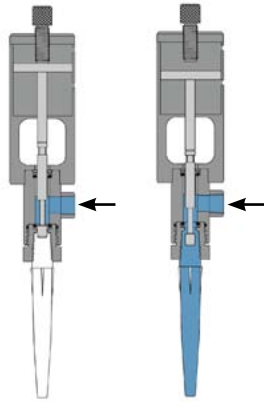

Needle On/Off Dispense Valve

Material flow commences when the needle retracts from its seat and stops when the needle reseats.

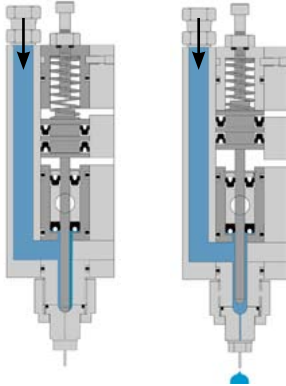

Pinch On/Off Dispense Valve

Material flow commences when the flexible dispense tubing pinch off is released and stops when the tube is pinched closed.

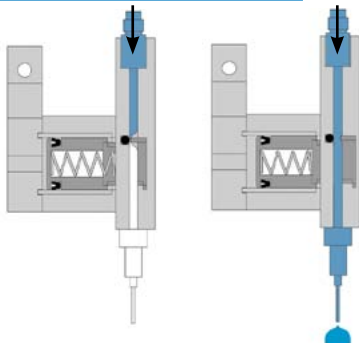

Positive Displacement Pinch Valve

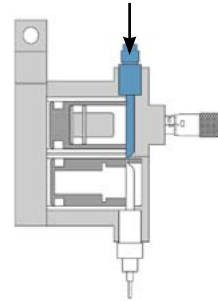

Fill Mode

In the fill mode, the resilient dispense tube is pinched by the bottom pinch off piston, closing the material path to the dispense needle. A pressurized reservoir fills the dispense tube to prepare for the next cycle. This is the normal "ready" state. The dispense cycle begins when the controller is activated.

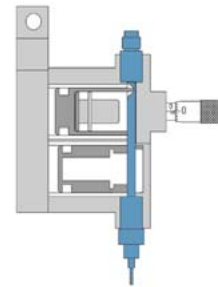

Dispense Delay

During the dispense delay, the top pinch off piston moves forward to stop the material supply from the reservoir and the bottom pinch off piston releases the dispense tube.

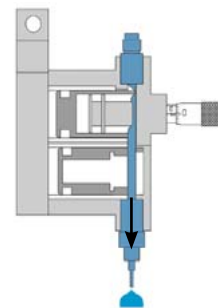

Dispense Mode

The dispense piston then moves forward until stopped by the micrometer stroke adjustment, squeezing a precise amount of material out of the dispense tube. When the dispense cycle is complete, the bottom pinch off piston seals off the dispense tube to prevent material drip. Immediately after, the dispense piston and top pinch off piston withdraw, allowing the material from the pressurized reservoir to refill the dispense tube. The system is again in the normal "ready" state.

Dispense Valve Technology

Positive Displacement Rod Valve With Spool Inlet/Outlet

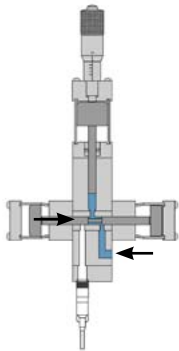

Fill Mode

In the fill mode, the spool is positioned over the inlet port, providing a material flow path from the material supply source to the metering chamber while blocking the outlet port. The metering rod is retracted to an adjustable micrometer hard stop which determines the volumetric output. The metering chamber is filled with material supplied from pressure tanks, cartridges or transfer pumps.

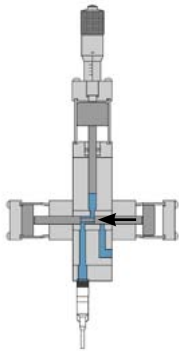

Dispense Delay

During dispense, the metering rod advances, blocking the material inlet port and pressurizing the metering chamber to overcome the outlet check valve.

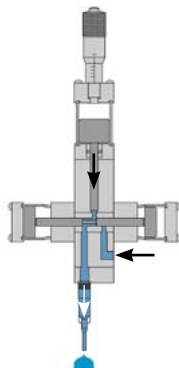

Dispense Mode

Dispense is achieved when the metering rod is advanced through the metering chamber, displacing the material. Upon completion of the travel in the metering chamber, the spool shifts back to the inlet port position, and the metering rod retracts to allow the metering chamber to refill.

Positive Displacement Rod Valve With Check Outlet

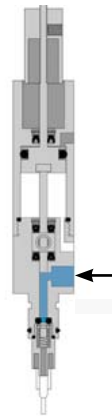

Fill Mode

In the fill mode, the metering rod is retracted against a calibrated hard stop, providing a material path to the metering chamber while the outlet check valve is held closed by spring tension. The metering chamber is filled with material supplied from pressure tanks, cartridges or syringes.

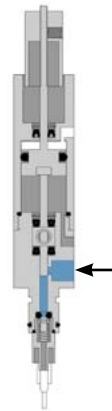

Dispense Delay

During dispense, the metering rod advances, blocking the material inlet port and pressurizing the metering chamber to overcome the outlet check valve.

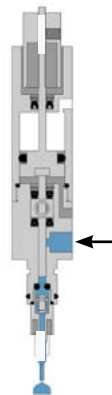

Dispense Mode

Dispense is achieved when the metering rod is advanced through the metering chamber, displacing the material. Upon completion of the metering stroke, the metering rod retracts, allowing the outlet check valve to close and then opening the material inlet port, allowing the metering chamber to refill.

Material Feed Systems

Gravity Feed

Metal Non-Pressure Tanks



Plastic Non-Pressure Tanks



Metal Pressure/Vacuum Tanks

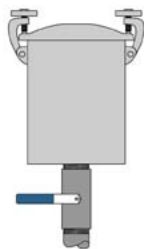

Dual 55 Gallon Drum Feed

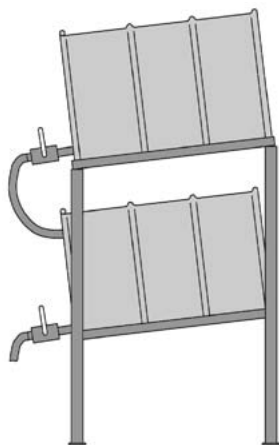

Pail Feed

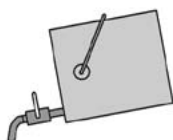

Drum Feed

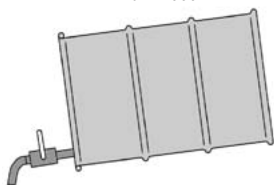

Feed System Options Include:

1. Agitation
2. Heating
3. Vacuum Degassing
4. Recirculation
5. Filters
6. Desiccant Air Dryer
7. Nitrogen Blanket
8. Stainless Steel Construction
9. PTFE Coating
10. Epoxy Coating
11. Follower Plates
12. Pressure Regulators
13. Level Controls
14. Sight Glasses
15. Slinger Plates
16. Support Stands
17. Various Types of Transfer Pumps
18. Single or Double Post Rams

Pressure Feed

Metal Pressure/Vacuum Tanks

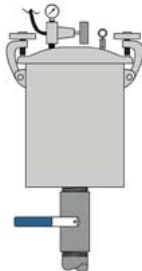

Syringe Receiver Caps



Cartridge Retainers

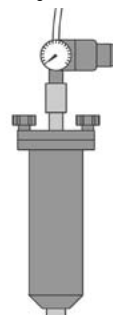

Cartridge Feed

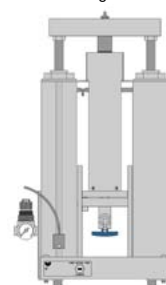

Transfer Pumps



Accumulator



Drum Ram/Follower Plate and Transfer Pump

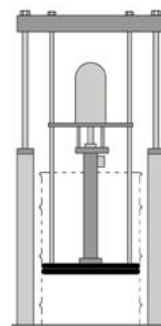

Pail Ram/Follower Plate and Transfer Pump

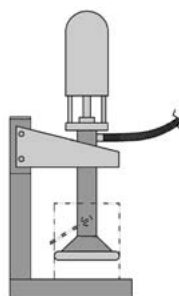

Viscosity

Viscosity is the measurement of a fluid's internal resistance to flow. This is typically designated in units of centipoise or poise but can be expressed in other acceptable measurements as well. Some conversion factors are as follows:

100 Centipoise = 1 Poise
 1 Centipoise = 1 mPa s (Millipascal Second)
 1 Poise = 0.1 Pa s (Pascal Second)
 Centipoise = Centistoke x Density

Newtonian materials are referred to as true liquids since their viscosity or consistency is not affected by shear such as agitation or pumping at a constant temperature. Water and oils are examples of Newtonian liquids.

Thixotropic materials reduce their viscosity as agitation or pressure is increased at a constant temperature. Ketchup and mayonnaise are examples of thixotropic materials. They appear thick or viscous but actually pump quite easily.

Paste viscosity is a vague term the viscosity of many materials but needs further definition to design a machine. Some paste viscosity materials will seek their own level or flow slowly and the shorter the time it takes, the easier they are to pump. Others do not seek their own level or flow at all and require pressure to move them from the supply container (cartridges, pails or drums) to the metering pump. These materials require special consideration regarding their feeding into metering pumps to assure the metering pump does not cavitate or to prevent air from being introduced into the material.

One way to differentiate between easy and difficult to flow pastes is to obtain Brookfield viscosities using the same spindle at two different rotational speeds, usually a tenfold difference (e.g. 1 RPM and 10 RPM). This will provide a "thixotropic index" for the particular material. The higher the difference in viscosity at the two speeds, the more thixotropic the material is and easier to pump.

To reduce the viscosity of paste materials to allow easier pumping, heat is often applied. The following graph illustrates how a typical filled epoxy resin reduces in viscosity as it is heated.

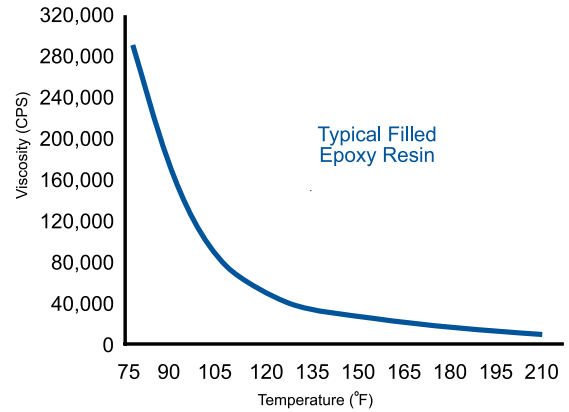

Solid materials at room temperature that are designed to be melted to allow pumping require heating above their melt point before they become a liquid. Maintaining heat on this material throughout the metering system (feed tank, pump, material supply hose, mixer, etc.) is normally critical to preventing this material from resolidifying somewhere in the system. A heated cabinet that encapsulates all wetted components of the machine is typically employed instead of just heat blanketing the various components.

Typically, the closer the "A" and "B" materials are in viscosity, the easier they will be to mix. The most difficult materials will have a high viscosity "taffy-like" consistency for one-component with a water thin viscosity as the other component.

Approximate Viscosities of Common Materials (At Room Temperature 70°F)

Material	Viscosity in Centipoise
Water	1 cps
Milk	3 cps
SAE 10 Motor Oil	85-140 cps
SAE 20 Motor Oil	140-420 cps
SAE 30 Motor Oil	420-650 cps
SAE 40 Motor Oil	650-900 cps
Castrol Oil	1,000 cps
Karo Syrup	5,000 cps
Honey	10,000 cps
Chocolate	25,000 cps
Ketchup	50,000 cps
Mustard	70,000 cps
Sour Cream	100,000 cps
Peanut Butter	250,000 cps

Viscosity

Viscosity Conversion Chart

Centipoise (CPS) or Millipascal (mPas)	Poise (P)	Centistokes (cSt)	Stokes (S)	Saybolt Universal (SSU)
1	0.01	1	0.01	31
2	0.02	2	0.02	34
4	0.04	4	0.04	38
7	0.07	7	0.07	47
10	0.1	10	0.1	60
15	0.15	15	0.15	80
20	0.2	20	0.2	100
25	0.24	25	0.24	130
30	0.3	30	0.3	160
40	0.4	40	0.4	210
50	0.5	50	0.5	260
60	0.6	60	0.6	320
70	0.7	70	0.7	370
80	0.8	80	0.8	430
90	0.9	90	0.9	480
100	1	100	1	530
120	1.2	120	1.2	580
140	1.4	140	1.4	690
160	1.6	160	1.6	790
180	1.8	180	1.8	900
200	2	200	2	1000
220	2.2	220	2.2	1100
240	2.4	240	2.4	1200
260	2.6	260	2.6	1280
280	2.8	280	2.8	1380
300	3	300	3	1475
320	3.2	320	3.2	1530
340	3.4	340	3.4	1630
360	3.6	360	3.6	1730
380	3.8	380	3.8	1850
400	4	400	4	1950
420	4.2	420	4.2	2050
440	4.4	440	4.4	2160
460	4.6	460	4.6	2270
480	4.8	480	4.8	2380
500	5	500	5	2480
550	5.5	550	5.5	2660
600	6	600	6	2900
700	7	700	7	3380
800	8	800	8	3880
900	9	900	9	4300
1000	10	1000	10	4600

Centipoise (CPS) or Millipascal (mPas)	Poise (P)	Centistokes (cSt)	Stokes (S)	Saybolt Universal (SSU)
1100	11	1100	11	5200
1200	12	1200	12	5620
1300	13	1300	13	6100
1400	14	1400	14	6480
1500	15	1500	15	7000
1600	16	1600	16	7500
1700	17	1700	17	8000
1800	18	1800	18	8500
1900	19	1900	19	9000
2000	20	2000	20	9400
2100	21	2100	21	9850
2200	22	2200	22	10300
2300	23	2300	23	10750
2400	24	2400	24	11200
2500	25	2500	25	11600
3000	30	3000	30	14500
3500	35	3500	35	16500
4000	40	4000	40	18500
4500	45	4500	45	21000
5000	50	5000	50	23500
5500	55	5500	55	26000
6000	60	6000	60	28000
6500	65	6500	65	30000
7000	70	7000	70	32500
7500	75	7500	75	35000
8000	80	8000	80	37000
8500	85	8500	85	39500
9000	90	9000	90	41080
9500	95	9500	95	43000
15000	150	15000	150	69400
20000	200	20000	200	92500
30000	300	30000	300	138500
40000	400	40000	400	185000
50000	500	50000	500	231000
60000	600	60000	600	277500
70000	700	70000	700	323500
80000	800	80000	800	370000
90000	900	90000	900	415500
100000	1000	100000	1000	462000
125000	1250	125000	1250	578000
150000	1500	150000	1500	694000
175000	1750	175000	1750	810000
200000	2000	200000	2000	925000

The viscosities given above are based on materials with a specific gravity of 1 g/cc.

Fillers

The Effect Of Common Fillers On The Construction Of Pumping Equipment

Filler is a general term used to describe an organic, non-metallic or metallic powder added to resins. They can extend material for cost reduction and/or enhance the material's mechanical properties.

Talc and calcium carbonate are soft fillers commonly used as extensions in materials. These fillers, or ones similar to them, can generally be used in pumping equipment of standard construction (mild steel hard chromed).

Silica and alumina (aluminum oxide) are fillers usually added to materials to enhance mechanical or thermal properties. These types of fillers often require special pump construction of nitrided steel or silicon carbide (ceramic) due to their hardness, physical size and/or shape.

A scale that measures the hardness of a material by its ability to indent or scratch another material was introduced in 1812 by Friedrich Mohs, a German mineralogist. The Mohs' Scale for minerals is arranged in a scale from 1 to 10, with 1 being the softest and 10 being the hardest. The Knoop Scale was developed as another method to determine hardness of a greater variety of materials.

Both the Mohs' Scale and the Knoop Scale provide important information concerning hardness of fillers as they relate to various pump materials of construction or other materials.

The charts shown on the next page provide data on various fillers that affect the construction of pumping equipment. For specific recommendations on pump construction for a particular material, contact Graco.

Filler Hardness Chart

Material	Commonly Used Fillers	Hardness Number	
		Mohs	Knoop
Pitch (for optical polishers)	Talc	1	1-22
Gypsum		2	32
Calcite	Calcium Carbonate	3	135
Flourite	Aluminum Trihydrate	4	163
Flint Glass		---	180-390
Apatite (parallel to axis)		5	360
Apatite (perpendicular to axis)		5	430
Crown Glass		---	420-470
Fused Quartz		---	475
Albite		6	490
Orthoclase		6	560
Crystalline quartz (parallel to axis)		7	710
Crystalline quartz (perpendicular to axis)	Silica	7	790
Nitrided annealed high-speed steel		---	800
Chromium plate		---	850-900
Carboly		---	1,050
Nitrided hardened high-speed steel		---	1,100
Topaz		8	1,250
Alundum	Alumina (Aluminum Oxide)	9	1,635
Silicon carbide		---	2,000
Boron carbide (molded)		---	2,230
Diamond		10	8000-8500

Fillers

Particle Size Chart

U. S. mesh	Inches	Microns
3	0.2650	6,730
3.5	0.2230	5,660
4	0.1870	4,760
5	0.1570	4,000
6	0.1320	3,360
7	0.1110	2,830
8	0.9370	2,380
10	0.7870	2,000
12	0.0661	1,680
14	0.0555	1,410
16	0.0469	1,190
18	0.0394	1,000
20	0.0331	841
25	0.0280	707
30	0.0232	595
35	0.0197	500
40	0.0165	420
45	0.0138	354
50	0.0117	297
60	0.0098	250
70	0.0083	210
80	0.0070	177
100	0.0059	149
120	0.0049	125
140	0.0041	105
170	0.0035	88
200	0.0029	74
230	0.0024	63
270	0.0021	53
325	0.0017	44
400	0.0015	37

Actual Particle Size

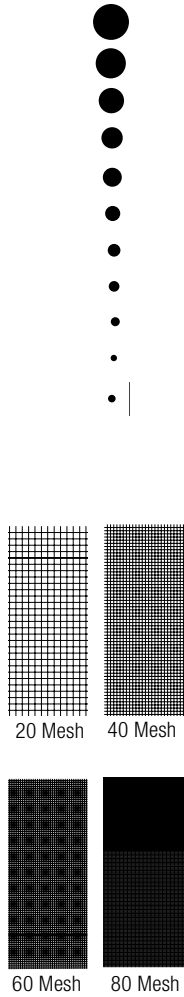

1 Micron = 0.001 MM
1 MM = 0.394 Inches

Durometer Chart

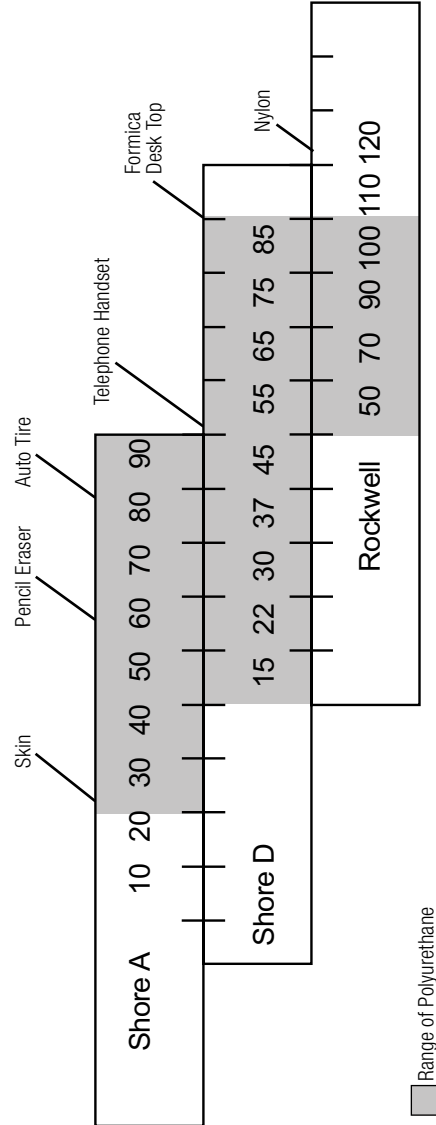

Hardness measurements of thermoset or thermoplastic materials, using Shore gauge.

Conversions and Formulas

Temperature Conversion Chart

This chart permits the conversion from degrees Celsius to degrees Fahrenheit or vice versa. Simply locate in bold face the number to be converted and read its conversion in the columns to the right or left of it. Degrees Celsius are identical to degrees Centigrade. The following formulas are used to calculate the conversions:

Fahrenheit to Celsius

$$T_c = \frac{5}{9} (T_f - 32)$$

Celsius to Fahrenheit

$$T_f = \left(\frac{9}{5}\right) T_c + 32$$

T_c = Temperature in Celsius
 T_f = Temperature in Fahrenheit

TO CONVERT		
To °C	← °F or °C →	To °F
-17.78	0	32
-17.22	1	33.8
-16.67	2	35.6
-16.11	3	37.4
-15.56	4	39.2
-15.00	5	41
-14.44	6	42.8
-13.89	7	44.6
-13.33	8	46.4
-12.78	9	48.2
-12.22	10	50
-11.67	11	51.8
-11.11	12	53.6
-10.56	13	55.4
-10.00	14	57.2
-9.44	15	59
-8.89	16	60.8
-8.33	17	62.6
-7.78	18	64.4
-7.22	19	66.2
-6.67	20	68
-6.11	21	69.8
-5.56	22	71.6
-5.00	23	73.4
-4.44	24	75.2
-3.89	25	77
-3.33	26	78.8
-2.78	27	80.6
-2.22	28	82.4
-1.67	29	84.2
-1.11	30	86
-0.56	31	87.8
0.00	32	89.6
0.56	33	91.4
1.11	34	93.2
1.67	35	95
2.22	36	96.8
2.78	37	98.6
3.33	38	100.4
3.89	39	102.2
4.44	40	104
5.00	41	105.8
5.56	42	107.6
6.11	43	109.4
6.67	44	111.2
7.22	45	113
7.78	46	114.8

TO CONVERT		
To °C	← °F or °C →	To °F
8.33	47	116.6
8.89	48	118.4
9.44	49	120.2
10.00	50	122.0
10.56	51	123.8
11.11	52	125.6
11.67	53	127.4
12.22	54	129.2
12.78	55	131.0
13.33	56	132.8
13.89	57	134.6
14.44	58	136.4
15.00	59	138.2
15.56	60	140.0
16.11	61	141.8
16.67	62	143.6
17.22	63	145.4
17.78	64	147.2
18.33	65	149.0
18.89	66	150.8
19.44	67	152.6
20.00	68	154.4
20.56	69	156.2
21.11	70	158.0
21.67	71	159.8
22.22	72	161.6
22.78	73	163.4
23.33	74	165.2
23.89	75	167.0
24.44	76	168.8
25.00	77	170.6
25.56	78	172.4
26.11	79	174.2
26.67	80	176.0
27.22	81	177.8
27.78	82	179.6
28.33	83	181.4
28.89	84	183.2
29.44	85	185.0
30.00	86	186.8
30.56	87	188.6
31.11	88	190.4
31.67	89	192.2
32.22	90	194.0
32.78	91	195.8
33.33	92	197.6
33.89	93	199.4

TO CONVERT		
To °C	← °F or °C →	To °F
34.44	94	201.2
35.00	95	203.0
35.56	96	204.8
36.11	97	206.6
36.67	98	208.4
37.22	99	210.2
37.78	100	212.0
43.33	110	230.0
48.89	120	248.0
54.44	130	266.0
60.00	140	284.0
65.56	150	302.0
71.11	160	320.0
76.67	170	338.0
82.22	180	356.0
87.78	190	374.0
93.33	200	392.0
98.89	210	410.0
104.44	220	428.0
110.00	230	446.0
115.56	240	464.0
121.11	250	482.0
126.67	260	500.0
132.22	270	518.0
137.78	280	536.0
143.33	290	554.0
148.89	300	572.0
154.44	310	590.0
160.00	320	608.0
165.56	330	626.0
171.11	340	644.0
176.67	350	662.0
182.22	360	680.0
187.78	370	698.0
193.33	380	716.0
198.89	390	734.0
204.44	400	752.0
210.00	410	770.0
215.56	420	788.0
221.11	430	806.0
226.67	440	824.0
232.22	450	842.0
237.78	460	860.0
243.33	470	878.0
248.89	480	896.0
254.44	490	914.0
260.00	500	932.0

Conversions and Formulas

Pressure Conversion Chart

TO CONVERT		
To psi	bar or psi	To bar
14.504	1	0.069
29.008	2	0.138
43.511	3	0.207
58.015	4	0.276
72.519	5	0.345
87.023	6	0.414
101.526	7	0.483
116.030	8	0.552
130.534	9	0.621
145.038	10	0.689
217.557	15	1.034
290.075	20	1.379
362.594	25	1.724
435.113	30	2.068
507.632	35	2.413
580.151	40	2.758
652.670	45	3.103
725.189	50	3.447
1,450.377	100	6.895
2,175.566	150	10.342
2,900.754	200	13.790
3,625.943	250	17.237
4,351.131	300	20.684
5,076.320	350	24.132
5,801.508	400	27.579
6,526.697	450	31.026
7,251.885	500	34.474
7,977.074	550	37.921
14,503.770	1,000	68.948

TO CONVERT		
To bar	kPa or bar	To kPa
0.010	1	100
0.020	2	200
0.030	3	300
0.040	4	400
0.050	5	500
0.060	6	600
0.070	7	700
0.080	8	800
0.090	9	900
0.100	10	1,000
0.150	15	1,500
0.200	20	2,000
0.250	25	2,500
0.300	30	3,000
0.350	35	3,500
0.400	40	4,000
0.450	45	4,500
0.500	50	5,000
1.000	100	10,000
1.500	150	15,000
2.000	200	20,000
2.500	250	25,000
3.000	300	30,000
3.500	350	35,000
4.000	400	40,000
4.500	450	45,000
5.000	500	50,000
5.500	550	55,000
10.000	1,000	100,000

TO CONVERT		
To psi	kPa or psi	To kPa
0.145	1	6.90
0.290	2	13.79
0.435	3	20.68
0.580	4	27.58
0.725	5	34.47
0.870	6	41.37
1.015	7	48.26
1.160	8	55.16
1.305	9	62.05
1.450	10	68.95
2.176	15	103.42
2.901	20	137.90
3.626	25	172.37
4.351	30	206.84
5.076	35	241.32
5.802	40	275.79
6.527	45	310.26
7.252	50	344.734
14.504	100	689.48
21.756	150	1,034.21
29.008	200	1,378.95
36.259	250	1,723.69
43.511	300	2,068.43
50.763	350	2,413.17
58.015	400	2,757.90
65.267	450	3,102.64
72.519	500	3,447.38
79.771	550	3,792.12
145.038	1,000	6,894.76

Conversions and Formulas

Useful Conversion Factors

Volume

1 Fluid Ounce	= 29.57 Cubic Centimeters
1 Gallon	= 3785 Cubic Centimeters
1 Gallon	= 3.785 Liters
1 Gallon	= 128 Fluid Ounces
1 Gallon	= 4 Quarts
1 Gallon	= 8 Pints
1 Gallon	= 16 Cups
1 Gallon	= 231 Cubic Inches
1 Gallon	= 0.134 Cubic Feet
1 Liter	= 0.264 Gallons
1 Liter	= 1.06 Quarts
1 Liter	= 1000 Milliliters
1 Cubic Foot	= 1728 Cubic Inches
1 Cubic Foot	= 7.48 Gallons
1 Cubic Inch	= 16.387 Cubic Centimeters
1 Cubic Centimeter	= 1 Milliliter
1 Microliter	= 0.001 cc's
1 Nanoliter	= 0.000001 cc's

Weight

1 Kilogram	= 1000 Grams
1 Kilogram	= 2.2 Pounds
1 Pound	= 16 Ounces
1 Pound	= 453.6 Grams
1 Pound	= 7000 Grains
1 Ounce	= 28.35 Grams

Length

1 Centimeter	= 10 Millimeters
1 Inch	= 2.54 Centimeters
1 Inch	= 1000 Mils
1 Foot	= 30.48 Centimeters
1 Yard	= 91.44 Centimeters
1 Mile	= 5280 Feet

Geometric Formulas

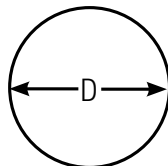

Circle

Area = πr^2 or $\pi D^2 \div 4$
 Circumference = πD or $2\pi r$
 (r = radius, D = diameter, π = 3.1416)

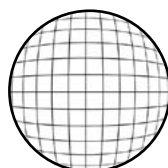

Sphere

Surface = $4\pi r^2$ or πD^2
 Volume = $D^3 \times 0.5236$

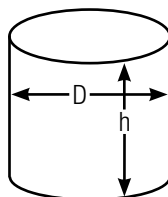

Cylinder

Volume = $\pi r^2 h$
 (h = height)

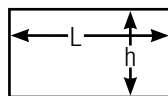

**Rectangle
or Square**

Area = $L \times h$
 (L = Length)

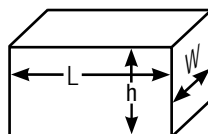

Box

Volume = $L \times W \times H$
 (W = Width)

Vacuum

Vacuum Pump Sizing

To determine the vacuum pump size which is designated in cubic feet per minute (CFM), the following information is needed:

- V = The volume of the tank(s) or vacuum chamber in cubic feet
- T = The time required to achieve a specific vacuum level in minutes
- F = A pump down factor for the specific vacuum pump which relates to the vacuum level required for the process

The formula for determining the vacuum pump size(s) is as follows:

$$S = \frac{V \times F}{T}$$

To determine the volume of standard tanks provided by Graco, refer to the following chart.

Tank Size	Volume
3 Liter	0.11 cubic feet
5 Liter	0.18 cubic feet
2 Gallon	0.27 cubic feet
5 Gallon	0.67 cubic feet
10 Gallon	1.34 cubic feet
15 Gallon	2.0 cubic feet
30 Gallon	4.0 cubic feet
60 Gallon	8.0 cubic feet

To determine the pump down factor, locate the desired vacuum level on the vertical axis. Then find where this intersects on the curve(s) and go straight down to the horizontal axis to find the pump down factor (F).

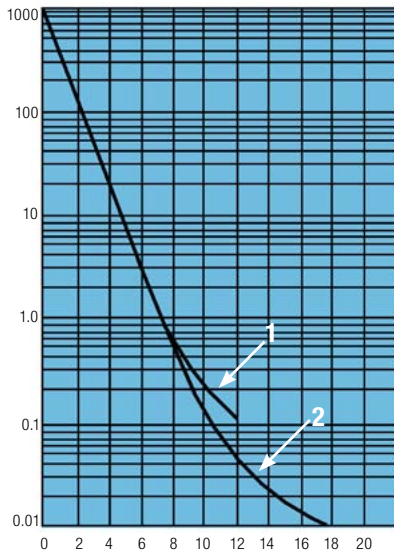

- 1 Single Stage Rotary Vacuum Pump
- 2 Two Stage Rotary Vacuum Pump

Note: This graph is for a specific manufacturer of vacuum pumps and can vary for other types of vacuum pumps. For reference only.

Vacuum Conversion Examples

1. What size vacuum pump is required for degassing a 30 gallon tank of material at a vacuum level of 10 Torr with the time required to achieve that vacuum level in the tank being 2 minutes?

$$S = \frac{V \times F}{T}$$

$$S = \frac{4.0 \times 5}{2}$$

$$S = \mathbf{10 \text{ CFM}}$$
 (minimum vacuum pump size)

Note: The time required to thoroughly degas the material is dependent on the amount of air in the material, the viscosity of the material, the design of the agitation and/or recirculation system, and many other variables. The pump sizing above only considers the time required to achieve a certain vacuum level.

2. How long will it take for a 6 CFM vacuum pump to achieve a 1 Torr vacuum level in a 5 gallon tank?

$$S = \frac{V \times F}{T} \quad \text{or} \quad \frac{T = V \times F}{S}$$

$$T = \frac{0.67 \times 7}{6}$$

$$T = \mathbf{0.78 \text{ minutes}}$$

Note: This assumes no vacuum leaks in the tank.

3. What size vacuum pump is required for achieving a 1 Torr vacuum level within 1 minute in a 2'x 2'x 2' vacuum chamber?

$$S = \frac{V \times F}{T}$$

$$S = \frac{8 \times 7}{1}$$

$$S = \mathbf{56 \text{ CFM}}$$
 (minimum vacuum pump size)

Vacuum

Vacuum Conversion Table

Torr or MM Mercury	Micron	PSI
760.0	760,000	14.7
750.0	750,000	14.5
735.6	735,600	14.2
700.0	700,000	13.5
600.0	600,000	11.6
500.0	500,000	9.7
400.0	400,000	7.7
380.0	380,000	7.3
300.0	300,000	5.8
200.0	200,000	3.9
100.0	100,000	1.93
90.0	90,000	1.74
80.0	80,000	1.55
70.0	70,000	1.35
60.0	60,000	1.16
51.7	51,700	1.00
50.0	50,000	0.97
40.0	40,000	0.77
30.0	30,000	0.58
25.4	25,400	0.4912
20.0	20,000	0.39
10.0	10,000	0.193
7.6	7,600	0.147
1.0	1,000	0.01934
0.75	750	0.0145
0.1	100	0.00193
0.01	10	0.000193
0.00	0	0

Inches Mercury Absolute	Inches Mercury Gauge	% Vacuum
29.92	0.0	0.0
29.5	0.42	1.3
28.9	1.02	1.9
27.6	2.32	7.9
23.6	6.32	21.0
19.7	10.22	34.0
15.7	14.22	47.0
15.0	14.92	50.0
11.8	18.12	61.0
7.85	22.07	74.0
3.94	25.98	87.0
3.54	26.38	88.0
3.15	26.77	89.5
2.76	27.16	90.8
2.36	27.56	92.1
2.03	27.89	93.0
1.97	27.95	93.5
1.57	28.35	94.8
1.18	28.74	96.1
1.00	28.92	96.6
0.785	29.14	97.4
0.394	29.53	98.7
0.299	29.62	99.0
0.03937	29.88	99.9
0.0295	29.89	99.9
0.00394	29.916	99.99
0.000394	29.9196	99.999
0	29.920	100.0

Application Data and Calculations

Power Factor (Intensification)

For air or hydraulically driven pumps, the power or intensification factor is determined by the drive piston(s) area divided by the fluid piston(s) area. This basically determines the output pressure and cycle rate capability of the pumping unit. The formula for calculating power factor is as follows:

$$\text{Power Factor} = \frac{\text{Area of drive cylinder(s)}}{\text{Area of fluid piston(s)}}$$

Example: A Posiratio machine with a 4" diameter air cylinder drive with a 30 mm diameter "A" pump and a 20 mm diameter "B" pump.

Area of 4" air cylinder = 81.07 cm²

Area of 30 mm piston = 7.07 cm²

Area of 20 mm piston = 3.14 cm²

$$\text{Power Factor} = \frac{81.07 \text{ cm}^2}{7.07 \text{ cm}^2 + 3.14 \text{ cm}^2}$$

$$\text{Power Factor} = 7.9:1$$

If 100 psi air pressure is applied to the 4" air cylinder, 790 psi fluid outlet pressure can be obtained in a stalled condition. If 50 psi air pressure is applied, only 395 psi fluid outlet pressure can be obtained.

The following is to be used as a guide only as the actual flow rate is dependent on a wide variety of factors including hose size, mixer size, fitting restrictions, injection block or gun employed, thixotropic characteristic of the material, heat, and any other factor that affects flow. Generally, the higher the power factor, the lower the volume output.

Power Factor "Rule Of Thumb" Chart

Viscosity in Centipoise	Approximate Power Factor Needed
50 to 500	1:1
500 to 1,000	2:1
1,000 to 3,000	3:1
3,000 to 6,000	4:1
6,000 to 9,000	5:1
9,000 to 15,000	6:1
15,000 to 20,000	7:1
20,000 to 30,000	8:1
30,000 to 40,000	9:1
40,000 to 60,000	10:1
60,000 to 75,000	11:1
75,000 to 90,000	12:1
90,000 to 120,000	13:1
120,000 to 200,000	14:1
200,000 to 1,000,000	15:1 to 20:1
over 1,000,000	Consult Factory

Air Cylinder Consumption

This chart is used for calculating the air consumption of a cylinder(s) on a reciprocating application to determine the total volume of air required to meet a given cycle rate. The values shown are for 100 psi which is the maximum pressure we recommend for operating the cylinder(s).

CYLINDER SIZE (I.D.)	AREA OF CYLINDER (sq. in)	(sq. cm)	SCFM (per 1" stroke at 100 psi)
1"	0.785	5.07	0.0035
1 1/2"	1.767	11.40	0.0080
2"	3.142	20.27	0.0142
2 1/2"	4.909	31.67	0.0223
3"	7.069	45.61	0.0319
4"	12.566	81.08	0.0566
6"	28.274	182.43	0.128
8"	50.266	324.31	0.222
10"	78.540	506.74	0.354
12"	113.098	729.71	0.512

Example:

Total air consumption of a 6" diameter air cylinder with a 6" stroke operating at 10 cycles per minute (20 strokes per minute):

$$6" \text{ Stroke} \times 0.128 \text{ SCFM}/1" \text{ Stroke} = 0.768 \text{ SCFM}$$

$$0.768 \text{ SCFM}/\text{Stroke} \times 20 \text{ Strokes}/\text{Min} = 15.36 \text{ SCFM}$$

Note:

To calculate total cylinder air consumption, both the forward and retract length of stroke need to be considered. Thus a 6" stroke air cylinder can travel a full 6" in each direction for a total of 12" of travel using 1.536 SCFM of air per cycle.

To determine actual power factor requirements for a specific flow rate, tests can be run at Graco's application laboratory with the specific material to be dispensed.

Application Data and Calculations

Volumetric Content and Ratio of Standard Material Hoses

Includes nylon high-pressure and PTFE-lined, stainless steel braided hose. The volumetric content of each size hose per lineal foot is provided in columns 3 and 4 in cubic inches (in³) and cubic centimeters (cc's). To determine the volumetric ratio of two equal length hoses, first locate one hose size in row 1 and the other hose size in column 1. At the point on the chart where these two hose sizes intersect, the volumetric ratio is given. (e.g. If "A" hose is 0.75" I.D. and the "B" hose is 0.375" I.D., the volumetric ratio between the two is 4.00:1 if they are of equal length.)

HOSE SIZE	TYPE OF HOSE	VOLUMETRIC CONTENT		0.125"	0.187"	0.250"
		in ³ /ft	cc's/ft			
0.125" (3/16)	PTFE/SS	0.147	2.414	1	2.24	4.00
0.187" (3/16)	Nylon or PTFE/SS	0.330	5.402		1	1.79
0.250" (1/4)	Nylon	0.589	9.655			1
0.312" (3/8)	PTFE/SS	0.917	15.037			
0.375" (3/8)	Nylon	1.325	21.723			
0.406" (1/2)	PTFE/SS	1.554	25.463			
0.500" (1/2)	Nylon	2.356	38.618			
0.625" (3/4)	PTFE/SS	3.682	60.341			
0.750" (3/4)	Nylon	5.301	86.891			
0.875" (1)	PTFE/SS	7.216	118.268			
1.000"	Nylon	9.425	154.472			

Note: The actual I.D.s of most PTFE/SS hoses is smaller than the hose designation. (eg. 1/2" PTFE/SS hose has an I.D. of 0.406")

0.312"	0.375"	0.406"	0.500"	0.625"	0.750"	0.875"	1.000"
6.23	9.00	10.55	16.00	25.00	36.00	49.00	64.00
2.78	4.02	4.71	7.15	11.17	16.08	21.89	28.60
1.56	2.25	2.64	4.00	6.25	9.00	12.25	16.00
1	1.44	1.69	2.57	4.01	5.78	7.87	10.27
	1	1.17	1.78	2.78	4.00	5.44	7.11
		1	1.52	2.37	3.41	4.64	6.07
			1	1.56	2.25	3.06	4.00
				1	1.44	1.96	2.56
					1	1.36	1.78
						1	1.31
							1

Generally, when designing a two-component meter, mix and dispense system, the volumetric ratios of the hoses should be close to the actual ratio of the resin system being dispensed assuming the "A" and "B" materials are of equal or close viscosity. When there are wide differences in viscosity of the two materials, then flow rate and pressure drop have to be taken into consideration and the hoses sized accordingly.

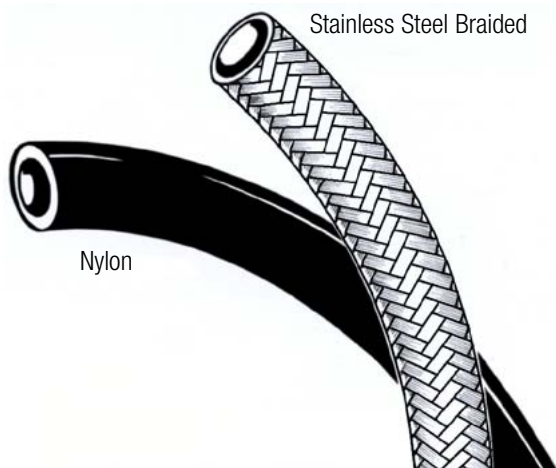

Application Data and Calculations

Volume of Dots

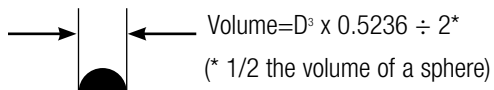

Dot Size

	V cc	0.00003		
D	Inch	0.02		•
	mm	0.51		
	V cc	0.0001		
D	Inch	0.03		•
	mm	0.76		
	V cc	0.0003		
D	Inch	0.04		•
	mm	1.02		
	V cc	0.0005		
D	Inch	0.05		•
	mm	1.27		
	V cc	0.001		
D	Inch	0.07		•
	mm	1.78		
	V cc	0.003		
D	Inch	0.09		•
	mm	2.29		
	V cc	0.006		
D	Inch	0.11		•
	mm	2.79		
	V cc	0.009		
D	Inch	0.13		•
	mm	3.30		
	V cc	0.014		
D	Inch	0.15		•
	mm	3.81		
	V cc	0.021		
D	Inch	0.17		•
	mm	4.31		

Dot Size

	V cc	0.029		
D	Inch	0.19		•
	mm	4.83		
	V cc	0.046		
D	Inch	0.22		•
	mm	5.59		
	V cc	0.059		
D	Inch	0.24		•
	mm	6.09		
	V cc	0.075		
D	Inch	0.26		•
	mm	6.6		
	V cc	0.116		
D	Inch	0.3		•
	mm	7.62		
	V cc	0.184		
D	Inch	0.35		•
	mm	8.89		
	V cc	0.275		
D	Inch	0.4		•
	mm	10.16		
	V cc	0.391		
D	Inch	0.45		•
	mm	11.43		
	V cc	0.536		
D	Inch	0.5		•
	mm	12.70		
	V cc	1.81		
D	Inch	0.75		•
	mm	19.05		

Application Data and Calculations

Volume of Bead

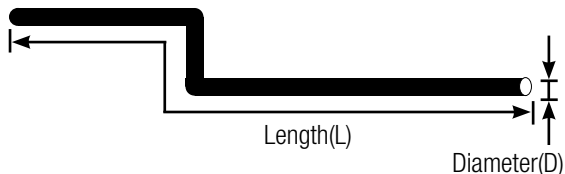

$$\text{Volume (cu.in.)} = \frac{\pi D^2(\text{in})}{4} \times L \text{ (in)}$$

$$\text{Volume (cc)} = \frac{\pi D^2(\text{cm})}{4} \times L \text{ (cm)}$$

Bead Size (D) = 0.0295" / 0.75 mm

Volume (cu. in.) = 0.0007 x Length (in)
Volume (cc's) = 0.0112 x Length (in)

Bead Size (D) = 0.0396" / 1.000 mm

Volume (cu. in.) = 0.0012 x Length (in)
Volume (cc's) = 0.0199 x Length (in)

Bead Size (D) = 0.0625" (1/16") / 1.588 mm

Volume (cu. in.) = 0.0031 x Length (in)
Volume (cc's) = 0.0500 x Length (in)

Bead Size (D) = 0.0937" (3/32") / 2.381 mm

Volume (cu. in.) = 0.0069 x Length (in)
Volume (cc's) = 0.1131 x Length (in)

Bead Size (D) = 0.125" (1/8") / 3.175 mm

Volume (cu. in.) = 0.0123 x Length (in)
Volume (cc's) = 0.2011 x Length (in)

Bead Size (D) = 0.1875" (3/16") / 4.763 mm

Volume (cu. in.) = 0.0276 x Length (in)
Volume (cc's) = 0.4525 x Length (in)

Bead Size (D) = 0.250" (1/4") / 6.350 mm

Volume (cu. in.) = 0.0491 x Length (in)
Volume (cc's) = 0.8044 x Length (in)

Bead Size (D) = 0.3125" (5/16") / 7.938 mm

Volume (cu. in.) = 0.0767 x Length (in)
Volume (cc's) = 1.2569 x Length (in)

Bead Size (D) = 0.375" (3/8") / 9.525 mm

Volume (cu. in.) = 0.1104 x Length (in)
Volume (cc's) = 1.8099 x Length (in)

Bead Size (D) = 0.500" (1/2") / 12.700 mm

Volume (cu. in.) = 0.1963 x Length (in)
Volume (cc's) = 3.2176 x Length (in)

Bead Size (D) = 0.625" (5/8") / 15.875 mm

Volume (cu. in.) = 0.3068 x Length (in)
Volume (cc's) = 5.0275 x Length (in)

Bead Size (D) = 0.750" (3/4") / 19.050 mm

Volume (cu. in.) = 0.4418 x Length (in)
Volume (cc's) = 7.2396 x Length (in)

Application Data and Calculations

Ratio of "A" to "B"

The mix ratio of a two (2) component thermoset resin system is generally given as either volume ratio or weight ratio. Since all meter, mix and dispense machines use volumetric displacement, it is important to understand the difference between these and how to convert from one to the other. The following formula can be used when the density or specific gravity of both the "A" and "B" components are known and only one of the ratios:

$$\frac{\text{Weight Ratio}}{\text{Volume Ratio}} = \frac{\text{Specific Gravity}}{\text{Specific Gravity}}$$

Example:

A material has a weight ratio of 10:1, the "A" material has a specific gravity of 1.20 and the "B" material has a specific gravity of 1.00. To calculate volume ratio:

$$\frac{10:1}{\text{Volume Ratio}} = \frac{1.20}{1.00}$$

$$\text{Volume Ratio} = \frac{10}{1.20}$$

$$\text{Volume Ratio} = 8.33:1$$

Typically the wider the ratio of "A" to "B" (e.g. 20:1, 50:1, 100:1), the more critical the design of the meter, mix and dispense machine. Not only do the metering pumps require more precise volumetric displacement but the selection of the injection block or dispense gun and mixer is equally as important. Closer mix ratios (eg. 1:1, 2:1, 5:1) will normally result in the simplest machine design.

Posiload Pump Sizing for Specific Ratios

To calculate the size of either the "A" or "B" pump for a fixed-ratio meter, mix and dispense machine, when the volume ratio is known along with one of the pump sizes, the following formulas can be used:

$$A = \sqrt{B^2 \times VR}$$

or

$$B = \frac{\sqrt{A^2}}{\sqrt{VR}}$$

Examples:

1. What size catalyst pump (B) is required for a volume ratio of 10:1 with a 40 mm resin pump (A)?

$$B = \frac{\sqrt{A^2}}{\sqrt{VR}}$$

$$B = \frac{\sqrt{40^2}}{\sqrt{10}} = \sqrt{160}$$

$$\mathbf{B = 12.649 \text{ mm}}$$

2. What size resin pump (A) is required for a volume ratio of 2.5:1 with a 15 mm catalyst pump (B)?

$$A = \sqrt{B^2 \times VR}$$

$$A = \sqrt{15^2 \times 2.5} = \sqrt{562.5}$$

$$\mathbf{A = 23.717 \text{ mm}}$$

Application Data and Calculations

Shot Capability of Standard Posiload Piston Pumps

Pump Size*	Maximum Shot (100%)	Minimum Shot (15%)
10 mm	5.98 cc's	0.90 cc's
15 mm	13.47 cc's	2.02 cc's
20 mm	23.94 cc's	3.59 cc's
25 mm	37.40 cc's	5.61 cc's
30 mm	53.86 cc's	8.08 cc's
35 mm	73.31 cc's	11.00 cc's
40 mm	95.75 cc's	14.36 cc's
45 mm	121.19 cc's	18.18 cc's
50 mm	149.62 cc's	22.44 cc's
55 mm	181.04 cc's	27.16 cc's
60 mm	215.45 cc's	32.32 cc's
70 mm	293.25 cc's	43.99 cc's
80 mm	383.02 cc's	57.45 cc's
90 mm	484.76 cc's	72.71 cc's
100 mm	598.47 cc's	89.77 cc's

*Special size pumps from 10 mm through 100 mm can be machined for specific shot requirements.

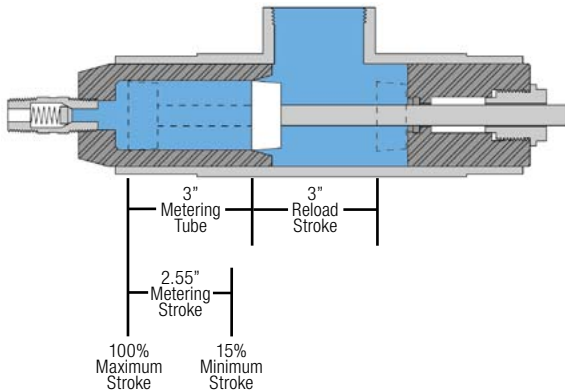

Gear Pump Selector Chart

Pump Outlet		Ratio Range			Flow rate at Min ratio		Flow rate at Mid ratio		Flow Rate
A cc/rev	B cc/rev	RATIO MAX	RATIO MID	RATIO MIN	MIN cc/sec	MAX cc/sec	MIN cc/sec	MAX cc/sec	MAX cc/sec
20	20	5.00	3.00	1.00	8	40	16	26	24
20	12	8.33	5.00	1.67	6.4	32	14.4	24	22.4
20	6	16.67	10.00	3.33	5.2	26	13.2	22	21.2
20	3	33.33	20.00	6.67	4.6	23	12.6	21	20.6
12	12	5.00	3.00	1.00	4.8	24	9.6	16	14.4
12	6	10.00	6.00	2.00	3.6	18	8.4	14	13.2
12	3	20.00	12.00	4.00	3	15	7.8	13	12.6
6	6	5.00	3.00	1.00	2.4	12	4.8	8	7.2
6	3	10.00	6.00	2.00	1.8	9	4.2	7	6.6
3	3	5.00	3.00	1.00	1.2	6	2.4	4	3.6

Flow Rate vs Ratio, 20/6 cc Pumps

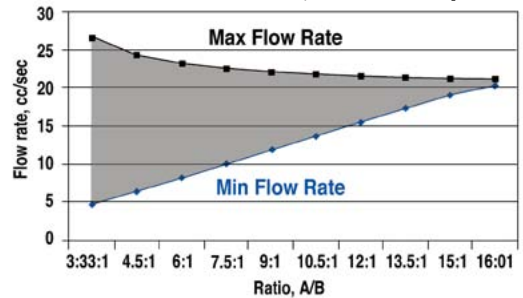

Flow Rate vs Ratio, 20/20 cc Pumps

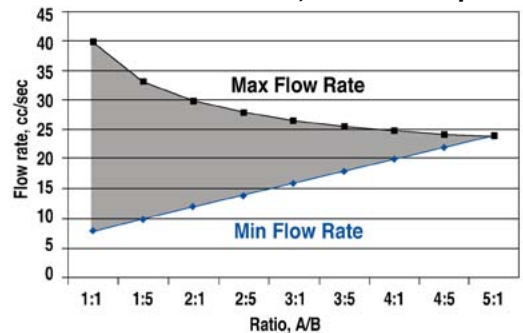

Application Data and Calculations

Conversion Chart

Production Throughput Planner

	Pieces per Minute	Pieces per Hour	Pieces per Day
			(8 Hours)
Seconds/Piece			
150 Sec.	0.4	24	192
60 Sec.	1	60	480
30 Sec.	2	120	960
12 Sec.	5	300	2,400
10 Sec.	6	360	2,888
6 Sec.	10	600	4800
3 Sec.	20	1,200	9,600
2 Sec.	30	1,800	14,400
1.5 Sec.	40	2,400	19,200
1.2 Sec.	50	3,000	24,000
1 Sec.	60	3,600	28,800
0.857 Sec.	70	4,200	33,600
0.750 Sec.	80	4,800	38,400
0.666 Sec.	90	5,400	43,200
0.600 Sec.	100	6,000	48,000
0.480 Sec.	125	7,500	60,000
0.400 Sec.	150	9,000	72,000
0.342 Sec.	175	10,500	84,000
0.300 Sec.	200	12,000	96,000

Pieces per Week	Pieces per Month	Pieces per Year
(40 Hours)	(21 Days)	(50 Weeks)
960	4,000	48,000
2,400	10,000	120,000
4,800	20,000	240,000
12,000	50,000	600,000
14,400	60,000	720,000
24,000	100,000	1,200,000
48,000	200,000	2,400,000
72,000	300,000	3,600,000
96,000	400,000	4,800,000
120,000	500,000	6,000,000
144,000	600,000	7,200,000
168,000	700,000	8,400,000
192,000	800,000	9,600,000
216,000	900,000	10,800,000
240,000	1,000,000	12,000,000
300,000	1,250,000	15,000,000
360,000	1,500,000	18,000,000
420,000	1,750,000	21,000,000
480,000	2,000,000	24,000,000

*Based on 100% Efficiency

Application Data and Calculations

Process Capability CP & CPK

Process capability is the ability of a given process to meet (customer's) expectations. It is measured by comparing the spread (variability) and centering of the process to the upper and lower specifications.

Tolerance – The difference between the upper and lower specifications

Variability (Spread) – Six times the process standard deviation (σ)

C_p – Measure of potential process capability

C_{pk} – Measure of actual process capability

$$C_p = \frac{USL - LSK}{6\sigma}$$

$$C_{pk} = \min \left\{ \frac{X - LSL}{3\sigma}, \frac{USL - X}{3\sigma} \right\}$$

X - Process average

USL - Upper Specification Limit

LSL - Lower Specification Limit

σ - Process Standard Deviation

$$\sigma = \frac{R}{d_2} \quad \sigma = \frac{S}{c_4}$$

R & S - average subgroup ranges and standard deviation

d_2 & c_4 - constant values based on subgroup sample sizes

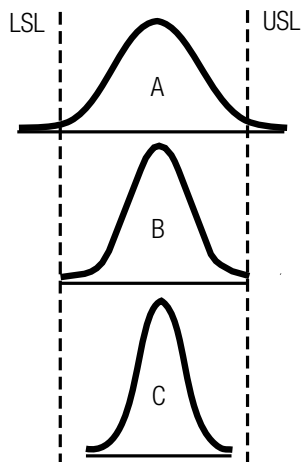

$C_p < 1$: The six-sigma process spread is greater than the tolerance.

$C_p = 1$: The six-sigma process spread is equal to the tolerance.

$C_p > 1$: The six-sigma process spread fits inside the tolerance.

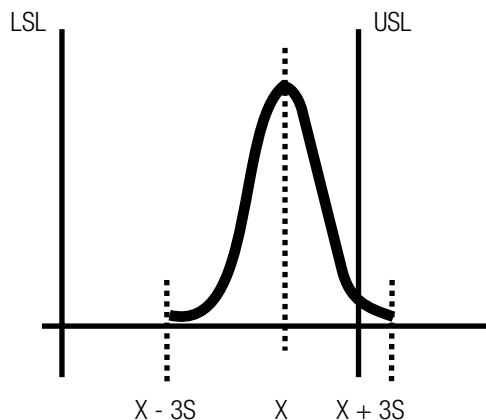

Results:

$C_{pk} < 1$ - Defective parts will be made, and the process is not in control.

$C_{pk} = 1$ - Minimum of 3% defectives will be made.

$C_{pk} \geq 1.33$ - The condition for the process to be considered in control.

Application Data and Calculations

Common Industry Abbreviations and Symbols

“A”	typically the high volume or resin component	kw	kilowatt
abs	absolute	kwhr	kilowatt hour
amb	ambient	lbs	pounds
ASTM	American Society for Testing Materials	lbs/cu ft	pounds per cubic foot
atm	atmosphere	M	meter
“B”	typically the low volume or catalyst component	mm	millimeter
BTU	British Thermal Unit	mPa s	Millipascal Second
°C	degrees Celsius or Centigrade	max	maximum
cc	cubic centimeter	min	minimum
cfm	cubic feet per minute	NEMA	National Electric Manufacturers Assoc.
cks	centistokes	NPS	National Std Pipe-Straight
cm	centimeter	NPT	National Std Pipe-Tapered
cps	centipoise	OD	outside diameter
cu	cubic	OSHA	Occupational Safety and Health Adm
cu ft	cubic feet	Pa s	Pascal Second
cu in	cubic inch	π	(Pi) 3.1416
deg	degrees	psi	pounds per square inch
°F	degrees Fahrenheit	psia	pounds per square inch absolute
FM	Factory Mutual	psig	pounds per square inch gauge
fpm	feet per minute	RIM	reaction injection molding
fps	feet per second	rpm	revolutions per minute
FRP	fiberglass reinforced plastic	RTM	resin transfer molding
ft	foot	RTV	room temperature vulcanizing
gal	gallons	scfm	standard cubic feet per minute
GPM	gallons per minute	SMC	Sheet Molding Compound
hg	mercury	sp gr	specific gravity
HP	horsepower	sq cm	square centimeter
hr	hour	sq ft	square foot
Hz	Hertz (cycles per second)	sq in	square inch
ID	inside diameter	SSU or SUS	Saybolt Universal Seconds
in	inch	std	standard
ISO	International Standards Organization	UHMW	ultra high molecular weight
JIC	Joint Industry Conference	UL	Underwriters Laboratory
kg	kilogram	vac	vacuum
km	kilometer	visc	viscosity
		VR	volume ratio
		WR	weight ratio

Application Glossary

Bonding - Joining securely through the use of adhesives.

Cartridge Filling - Dispensing a given volume of material into a customer-selected package.

Coating - Covering with a layer, such as a paint or protective material.

Doming - Preserving and enhancing the appearance of nameplates, labels or decals by applying a clear “dome” over a preprinted graphic.

Filament Winding - Coil winding or coating.

Gasketing - Sealing or packing between matched parts to prevent the exchange of gas or fluid and protect against environmental conditions.

Laminating - Uniting several layers of material with a flexible urethane.

LIM (Liquid Injection Molding) - Involves the injection of liquid polyurethane systems into a mold. The components then polymerize within the mold.

LSR (Liquid Silicone Rubber) - Is a two-part catalyzed product particularly well suited for high-production products with tight dimensional tolerances.

Molding - Injecting or pouring a reactive plastic fluid into a hollow form or matrix.

Potting - To embed in a container within an insulating or protective material. Potting is often accomplished within an evacuated environment, called vacuum encapsulation.

Pultrusion - Pulling glass fibers through a resin bath to make continuous profiles, pipes and other shapes.

Rapid Prototyping - Casting void-free parts for fast-curing polyurethanes for quick mold turnarounds.

RIM (Reaction Injection Molding) - Involves the injection of liquid polyurethane systems into a mold. The components then polymerize within the mold.

RTM (Resin Transfer Molding) - Is a closed mold process for molding fiberglass products. It does not require metal molds or high pressure mold closing systems. It is ideal for part volumes from 500 to 10,000 parts per year.

Robotics - Refers to equipment that works automatically or by remote control.

Scripting - Using three-dimensional automation to produce decorative fonts by dispensing a precise amount of material to give the lettering a raised effect.

Sealing - Closing or securing a part or assembly with a fluid-tight, air-tight adhesive.

VARTM (Vacuum-Assisted Resin Transfer Molding) - Is a low-cost alternative to resin transfer molding (RTM). It features lower tooling costs, room temperature processing and ease of scalability.

Automation Terms

Accuracy – Is the difference between the series of measurements empirically obtained and the theoretically expected position.

Repeatability – Is the degree of variation of the various measurements taken when the system is asked to move to a given point.

Resolution – Smallest attainable increment of positioning.

Nominal Life Expectancy – Is the accumulative linear meters of travel the motion manufacturer guarantees that the system will achieve or exceed before indications of fatigue are seen. Load and operating conditions can greatly vary the specification.

$$L = \left(\frac{C}{P}\right)^p \times 1 \times 10^6 \text{ m}$$

$$L_h = \frac{1666}{V} \left(\frac{C}{P}\right)^p$$

L [m] - nominal life expectancy in meters

L_h [h] - nominal life expectancy in operating hours

C [N] - dynamic load (provided by manufacturer)

P [N] - dynamic equivalent load (actual load)

p - Life expectancy index:
ball bearing linear guides: p=3
roller bearing linear guides: p =10/3

v [m/min] - average travel speed

ABOUT GRACO

Founded in 1926, Graco is a world leader in fluid handling systems and components. Graco products move, measure, control, dispense and apply a wide range of fluids and viscous materials used in vehicle lubrication, commercial and industrial settings.

The company's success is based on its unwavering commitment to technical excellence, world-class manufacturing and unparalleled customer service. Working closely with qualified distributors, Graco offers systems, products and technology that set the quality standard in a wide range of fluid handling solutions. Graco provides equipment for spray finishing, protective coating, paint circulation, lubrication, and dispensing sealants and adhesives, along with power application equipment for the contractor industry. Graco's ongoing investment in fluid management and control will continue to provide innovative solutions to a diverse global market.

GRACO LOCATIONS

MINNESOTA

Worldwide Headquarters
Graco Inc.
88-11th Avenue N.E.
Minneapolis, MN 55413

OHIO

Graco Ohio Inc.
8400 Port Jackson Ave NW
North Canton, OH 44720
Tel: 330-966-3000
Fax: 330-494-5383

SALES/ SERVICE

Call today for product information or to request a demonstration. **800-746-1334** or visit us at www.graco.com or www.liquidcontrol.com